

TECHNICAL SPECIFICATION

MODEL STS-1 SHORT PERCH TUBE FACING AND SQUARING MACHINE

The STS-1 Tube Squaring Tool is designed specifically to prepare tube for autogenous welding. The STS-1 will face .125" (3.2mm) to 1.125" (28.6mm) outside diameter tubing with a wall thickness up to .125" (3.2mm). The STS-1 uses an OD saddle clamping system for holding and rounding the tube. The STS-1 accepts its own torque through the saddle clamping system. The standard saddle clamping system requires a straight length of tube .60" (15.2mm) long. The Short Perch saddle clamping system requires a straight length of tube .19" (4.8mm) long. Speed is controlled by a variable speed electric motor. Feed is actuated by rotating an inline feed collar.

The Model STS-1 System comes complete with:

- Carrying Case
 - Operator's Manual
-

Accessories

- Bench Stand Assembly
-

Design and Operating Features

- The Model STS-1 is lightweight and easy to handle
- Variable speed brushless cordless electric motors
- Variable speed corded electric motors
- Standard and short perch saddle clamps
- The cutting head accepts Squaring Tool Bits
- The STS-1 accepts its own torque through the saddle clamping system
- Integral chip guards
- Inline feed with .20" (5.0mm) of travel

Specifications

Reference Envelope Drawing No. 77-1857 (Model STS-1 Cordless Metabo)

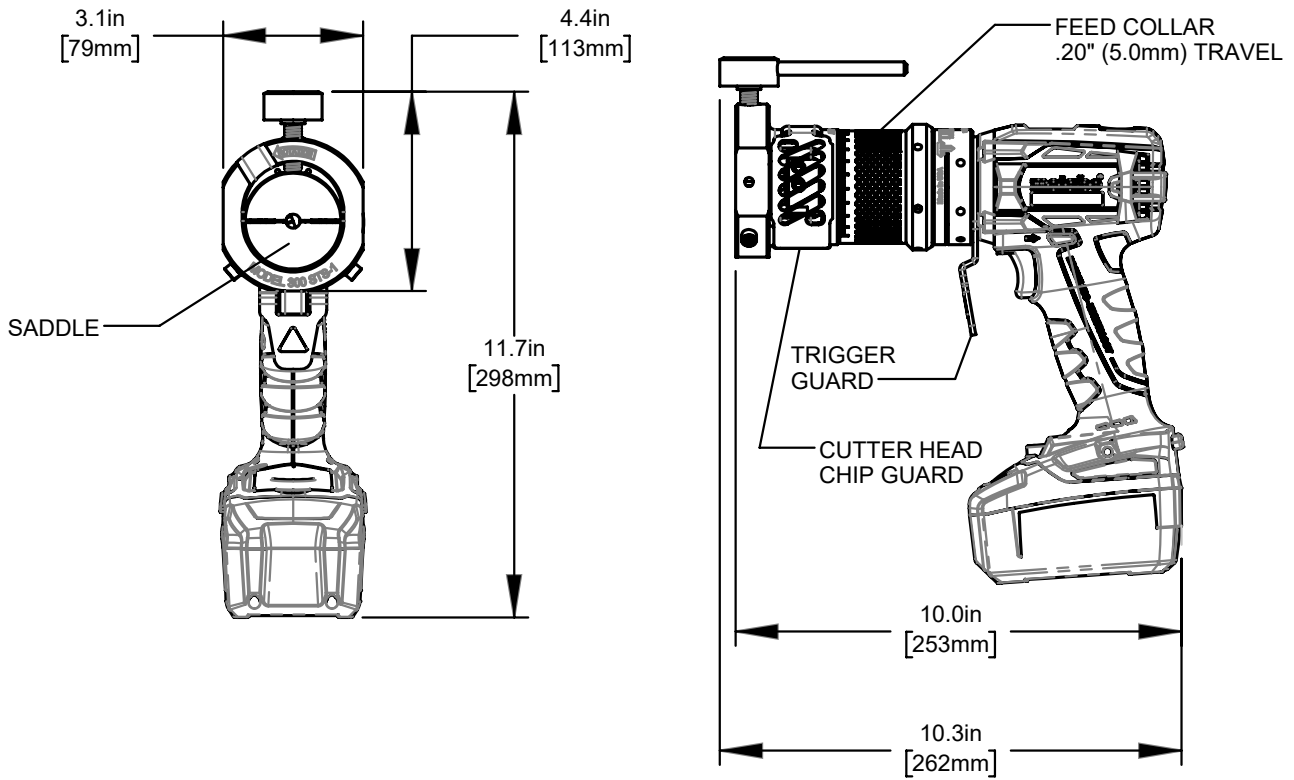

Reference Envelope Drawing No. 77-1858 (Model STS-1 Corded 115V & 230V Metabo)

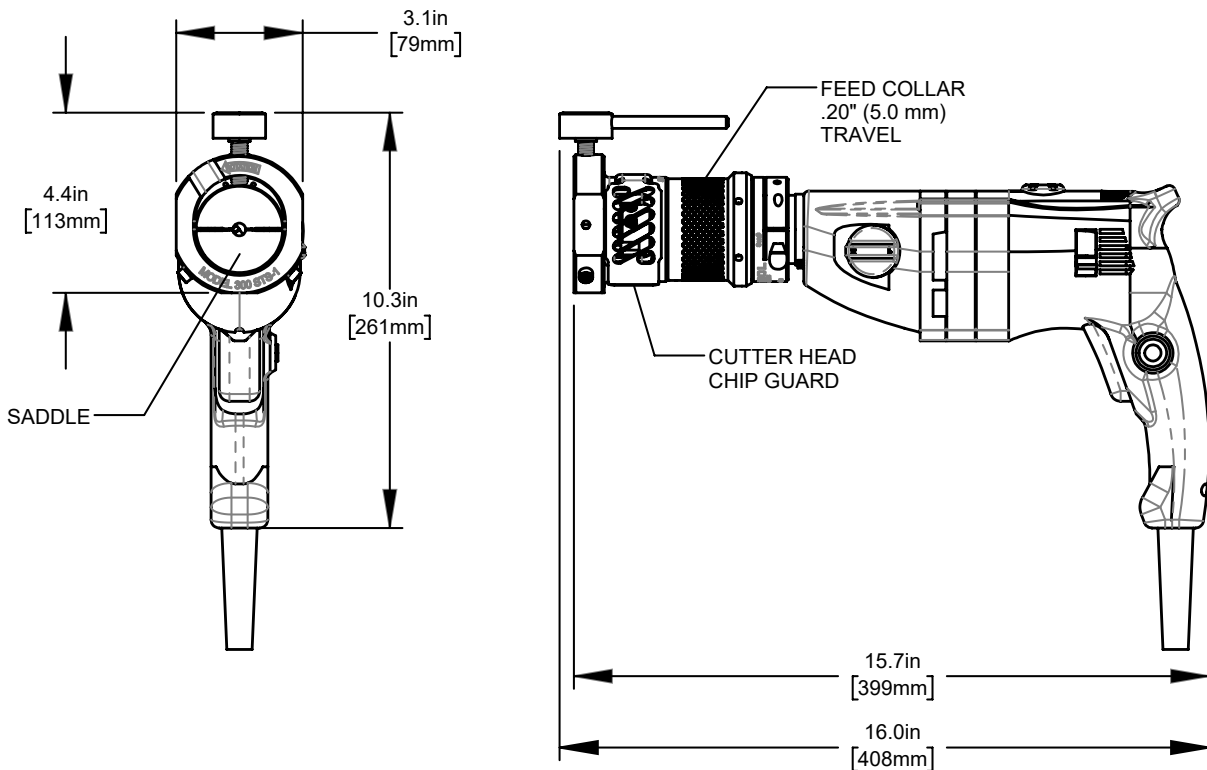

Clearance and Dimensions

Weight:

- Base machine 3.1 lbs. (1.4 Kg)
 - Cordless Metabo Motor 4.2 lbs. (1.9 Kg)
 - Corded Metabo Motor 5.6 lbs. (2.5 Kg)
 - Corded Makita Motor (Japanese Version) 5.3 lbs. (2.4 Kg)
 - Cordless Dewalt Motor (Japanese Version) 4.0 lbs. (1.8 Kg)
-

Pipe Cutting Capacities

Basic Pipe Sizes:

- 1/8" All schedules
- 1/4" All schedules
- 3/8" All schedules
- 1/2" Schedules 5 through 40
- 3/4" Schedules 5 through 40

Basic Tube Sizes:

.125" (3.2mm) to 1.125" (28.6mm)

Maximum Wall Thickness .125" (3.2mm)

Material Cutting Capabilities

- Chrome steels (20% max)
 - Stainless steel
 - Copper-nickel alloys and Aluminum without limitations except size and wall thickness
 - Carbon steel
 - Copper
-

Drive Motor Options

- 18VDC Metabo Brushless Cordless Motor Assembly with 115VAC Charger
 - 18VDC Metabo Brushless Cordless Motor Assembly with 230VAC Charger
 - 115VAC 50/60 Hz 9.6 Amp Metabo Corded Motor Assembly
 - 230VAC 50/60 Hz 5.7 Amp Metabo Corded Motor Assembly
 - 100VAC 50/60 Hz 7.2 Amp Makita Corded Motor Assembly (For Japan Only)
 - 18VDC Dewalt Brushless Cordless Motor Assembly (For Japan Only)
-

Note To The Customer

Spare Parts and Standard Tool Bits are available from stock. Engineering design services for custom tool bits and special function modifications are available from the factory.

All Tri Tool Technologies and allied equipment products are subject to design improvements and specification changes at any time with no obligation to units already sold.

Warranty (limited): Parts and equipment are warranted against defects in material and workmanship for a period of one (1) year from date of purchase. Full details supplied on request and/or with the tools.



www.tritool.com



[@tritooltechnologies](https://www.facebook.com/tritooltechnologies)



[@tritooltech](https://www.linkedin.com/company/tritooltech)



[@tritooltechnologies](https://twitter.com/tritooltechnologies)



3041 Sunrise Blvd
Rancho Cordova, CA 95742
+916-288-6100
+1-800-345-5015
Fax 916-288-6160

Copyright © Proprietary property of Tri Tool Technologies. No reproduction, use or duplication of the information shown hereon is permitted without the express written consent of Tri Tool Technologies.