

## TECHNICAL SPECIFICATION MODEL 204BE – 115V BEVELMASTER™ SYSTEM

The Model 204BE - 115V BEVELMASTER™ is a portable ID mounting weld end preparation machine tool for light duty beveling, facing and counterboring of pipe or tubing ends in preparation for welding.

### The Model 204BE – 115V BEVELMASTER™ System comes complete with:

- Model 204 B Sub-Assembly 1 ea.
- Head Kit, Cutting, 4" Dia. w/ cam 1 ea.
- Electric Motor Assembly (3/4" HP) 1 ea.
- Mandrel Assembly 1 ea.
- Jaw Block Set 1 ea.
- Wrench Kit 1 ea.
- Carrying Case 1 ea.
- Operator's Manual 1 ea.

### Special Features

- Mandrel shaft heat treated to Rc 50 for optimum strength and hardness minimum wear.
- Heavy duty tapered mandrel and spindle bearings.
- Mandrel shaft seal to keep coolants out of the gears.
- Heat-treated mandrel mounting blocks for maximum life and secure mounting. Heavy duty gear reduction for optimum performance.
- Cutting Head with Facing Bit Cam for ease of Land thickness adjustment.

The Model 204B BEVELMASTER™ will secure to pipe and tubing having an inside diameter ranging from 1.25" (31.8 mm) through 4.33" (110.0 mm).

---

### Design and Operating Features

- The lathe accepts its own torque through the mandrel.
- The expanding mandrel provides fast, accurate self-centering and alignment.
- All wrenches needed for operation (less Tool Bits) are provided with the system.
- The lathe is lightweight, at less than 18 lbs. (8.16 Kg). Easily handled by one operator.

# Specifications

Reference Envelope Drawing No.: 77-1666

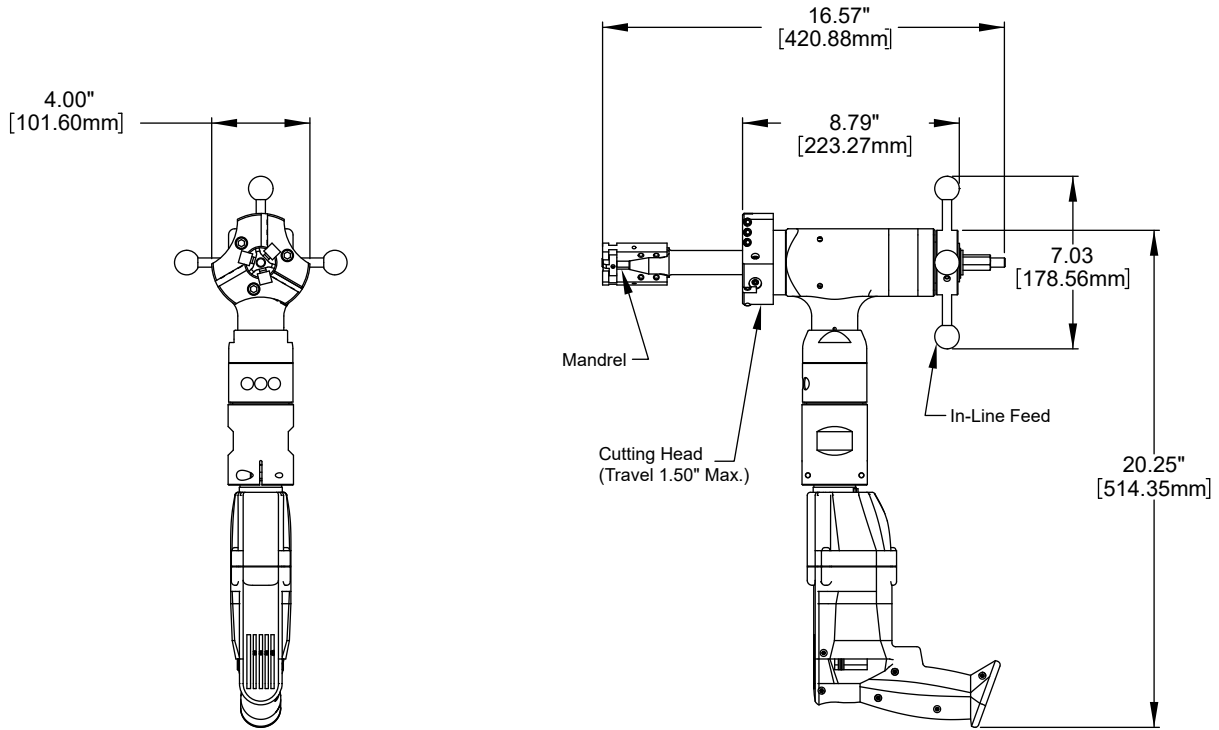

## Pipe Cutting Capacities

### Basic Pipe Sizes

1" Pipe

Schedule 40 (Small Mandrel required to mount in 1" schedule 80 and above.)

1 1/4" through 2 1/2" Pipe

Up to Schedule 80

3" through 4" Pipe

Up to Schedule 40

*Note: Some Schedules may require optional equipment.*

### Basic Tube Sizes

Up to .250" (6.4 mm) wall tubing with a maximum OD of 4.50" (114.3 mm) and a minimum ID of 1.25" (31.7 mm) may be beveled with standard mandrel.

### Wall Thickness Capacity (Limitations)

Wall thickness of schedules listed, .276" (7 mm) maximum, in the range listed can be machined without limitations.

Wall thicknesses greater than .276" (7 mm) require special procedures and are subject to Duty Cycle limitations to prevent motor damage. Contact Tri Tool Technologies for heavier wall procedures.

### Counterboring Operations

The tool will counterbore pipe and tubing with an ID of 1.50" (38.1 mm) to 4.33" (110.2 mm).

## Duty Cycle

The 204BE with an electric motor (P/N 58-0147 or equivalent) duty cycle on high cutting load applications (see above), is limited to 50% 'On' time with a maximum of five (5) minutes continuous 'On' time.

---

## Material Cutting Capabilities

Mild steels, chrome steels, (Rc 35 max), stainless steel, copper-nickel alloys and aluminum without limitations except size and wall thickness as specified in the above paragraphs.

Inconel and some other high temperature alloys may require special procedures as a function of wall thickness and type of end preparations. Contact Tri Tool Technologies' Engineering Department for details.

---

## Clearance and Dimensions

Rotating Head DIA.	4.00" (101.6 mm)
Length	8.97" (227.8 mm)
Length Over Motor	20.25" (514.35 mm)
Available Feed Travel	1.50" (38.1 mm)

---

## Drive System

Final Drive	Gear Driven
Electric Motor - 2 speed Ranges & 6:1 Gear Reduction:	
Free speed	
Low Range: 168 rpm	High Range: 316 rpm
Max. HP Speed	
Low Range: 112 rpm	High range: 210 rpm

## Power Requirements

115 VAC, 5.25 Amps, 28 to 60 Hz.

---

## Cutting Head Speeds

Max. Cutting Head Speed	
Low Range: 84 rpm	High Range: 156 rpm
Cutting Head Speed @ Max. H.P.	
Low Range: 56 rpm	High Range: 105 rpm
Functional Speed Range	20 to 100 rpm

---

## Speed Control

On/Off Trigger control with Variable Speed.

---

## Mounting

Manually actuated draw rod expands mandrel ramps and jaw blocks.

---

## Feed

Manual-Feed Handle is in line at the back of the machine. Feed rate is .100" (2.5mm) per revolution of the feed handle.

---

## Accessories

- Mandrel Assembly, Reduced DIA., 1.00" (25.4 mm) to 1.25" (31.8 mm) range.
- Mandrel Assembly, Reduced DIA., .610" (15.5 mm) to 1.00" (25.4 mm) range.
- Flange Facer Kit
- Elbow Mandrel Kit
- Elbow Mandrel Squaring Plate
- Elbow Mandrel Adjustable Pin Kit
- Pointer Kit, Elbow Mandrel
- Mandrel Assembly, Small Elbows

### Note To The Customer

Spare Parts and Standard Tool Bits are available from stock. Engineering design services for custom tool bits and special function modifications are available from the factory.

All Tri Tool Technologies and allied equipment products are subject to design improvements and specification changes at any time with no obligation to units already sold.

Warranty (limited): Parts and equipment are warranted against defects in material and workmanship for a period of one (1) year from date of purchase. Full details supplied on request and/or with the tools.

 [www.tritool.com](http://www.tritool.com)

 @tritooltechnologies

 @tritooltech

 @tritooltechnologies



3041 Sunrise Blvd  
Rancho Cordova, CA 95742  
+916-288-6100  
+1-800-345-5015  
Fax 916-288-6160

Copyright © Proprietary property of Tri Tool Technologies. No reproduction, use or duplication of the information shown hereon is permitted without the express written consent of Tri Tool Technologies.

---