

# OPERATION MANUAL

92-0756 Rev. 241115  
Model 300MF MICROFACER™



## ABOUT TRI TOOL TECHNOLOGIES



At Tri Tool Technologies, we are committed to your success through relentless innovation and powerful partnership. We insist on developing tools and equipment that exceed your expectations of performance, precision, safety, and durability. As a full-service engineering firm, we are here to support you every step of the way.

For more information on engineered solutions, products, and trainings, visit [tritool.com](http://tritool.com) or contact our engineers at +1 (916) 288-6100.

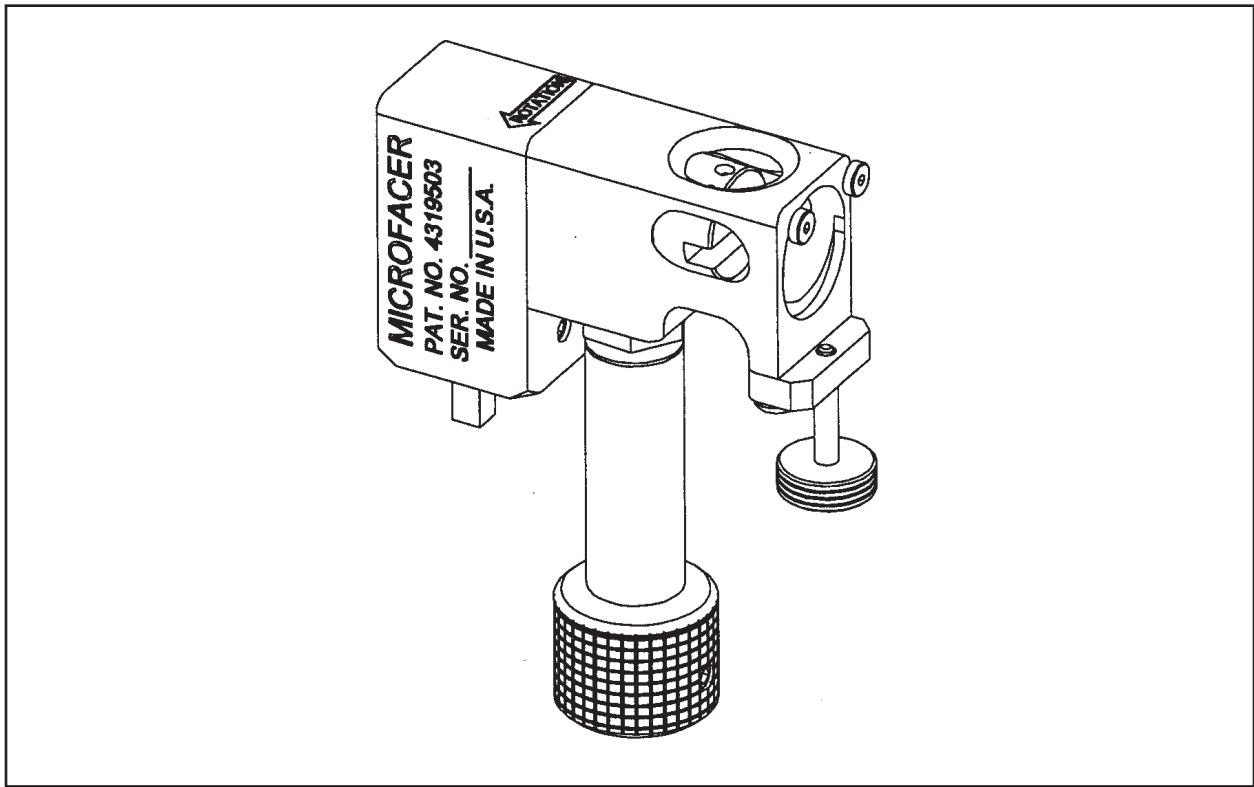

## TABLE OF CONTENTS

TRI TOOL TECHNOLOGIES WARRANTY	2
TOOL BIT RESHARPENING POLICY	3
ABOUT THE MANUAL	4
SAFETY PRECAUTIONS	6
GENERAL DESCRIPTION	8
SPECIFICATIONS	9
MAINTENANCE	10
OPERATION	11
CUTTING SPEEDS AND FEEDS	13
SADDLE SETS	14
TOOL BITS	16
TROUBLESHOOTING	17
ACCESSORIES	19
MAKITA SAFETY INSTRUCTIONS	19
RECOMMENDED SPARE PARTS	20
ILLUSTRATED PARTS BREAKDOWN	22

## **Tri Tool Technologies Warranty**

LIMITED WARRANTY: All products manufactured by Seller are warranted to be free from defects in materials and workmanship under normal use. The period of this warranty shall be three years from the date of shipment for all products, except for welding and Non-Standard Products which shall be one year from the date of shipment. The Buyer shall bear all shipping, packing and insurance costs and all other costs to and from a designated repair service center. All return goods must be authorized in advance and communicated upon issuance of a Return Material Authorization (RMA) by Seller. The product will be returned to the Seller accompanied by a RMA number and associated paperwork, freight prepaid and billed to the Buyer. This warranty is not transferable and will not apply to tool bits or other consumables, or to any Goods to have been (i) mishandled, misused, abused or damaged by Buyer or any third party; (ii) altered without the express permission in writing by Seller, (iii) repaired by a party other than Seller without Seller's prior written approval; or (iv) improperly stored, installed, operated, or maintained in a manner inconsistent with Seller's instructions. This warranty does not apply to defects attributed to (i) normal wear and tear or (ii) failure to comply with Seller's safety warnings.

No warranty for any parts or other supplies provided to seller by buyer, whether or not they are incorporated into goods. Goods supplied by seller which are designed or manufactured by a third party are subject strictly to the third party's warranty for those goods. Seller makes no warranty and disclaims all statutory or implied warranties for these goods, including the implied warranties of merchantability, freedom from patent infringement and fitness for a particular purpose.

Neither this warranty nor any other warranty, expressed or implied, including implied warranties of mechanical ability, fitness for a particular use, or merchantability, shall extend beyond the warranty period. No responsibility is assumed for any incidental or consequential damages. Some states do not allow limitations on how long an implied warranty lasts and some states do not allow the exclusion or limitations incidental or consequential damages, so the above limitation of exclusion does not apply to all Buyers. This warranty gives the Buyer specific legal rights. Other rights vary from state to state.

## **Warranty Claims and Remedies**

Buyer must promptly notify Seller in writing during the applicable warranty period, of any defective Goods covered by Seller's warranties under the Limited Warranty section herein, and no later than fifteen (15) calendar days after discovery of the defect. Seller has no obligation to honor any warranty claim made after the expiration of the warranty period. However, despite the expiration of the warranty period, Seller, at its reasonable discretion, may accept warranty claims submitted up to fifteen (15) calendar days after the expiration of the warranty period provided that Buyer provides Seller with credible and persuasive documentary evidence that the defect was discovered during the warranty period. No warranty claims submitted after this fifteen (15) day calendar period will be considered by Seller.

Buyer's notice of a defective Goods must identify the specific Goods affected, and the nature of the defect. It is required when returning the defective Goods, that it is suitably packed, fully insured, and transportation and insurance prepaid in accordance with instructions issued by Seller. Seller, at its sole option, will either repair or replace any Goods authorized for return to Seller. Such repair, replacement, or credit shall be Buyer's sole remedy for defective Goods. Buyer must promptly provide Seller with all information requested regarding the identified defect.

If the defect claimed by Buyer cannot be reproduced or otherwise verified by Seller, the Goods will be returned to Buyer unmodified at Buyer's expense.

The warranty period for repaired or replaced Goods shall be (i) ninety (90) days or (ii) the unexpired portion of the original warranty period. Under no circumstances is Seller liable for recall, retrieval, removal, dismantling, re-installation, redeployment, or re-commissioning of any defective Goods or any costs associated therewith.

## Tool Bit Resharpener Policy

Buyer is required to check all tool bits prior to returning and ensure they are packaged well for shipment. The price structure is available from the Seller's sales coordinator. Seller cannot resharpen badly gouged, chipped, or broken tool bits. Seller will return tool bits that are not suitable for resharpening with the tool bits that were resharpened upon Buyer's request. Buyer is responsible for all shipping charges to and from Seller.



# 1. ABOUT THE MANUAL

## Copyright

©Copyright Tri Tool Technologies. Proprietary property of Tri Tool Technologies. No reproduction, use, or duplication of the information shown hereon is permitted without the express written consent of Tri Tool Technologies.

## Disclaimer

The instructions and descriptions in this manual were accurate when the manual was written. However, the information in the manual is subject to change without notice. Check for updated information before you start any job. The Tri Tool Technologies web site has the most current information.

Do not operate or work on this equipment unless you have read and understood the instructions in this Manual. Failure to follow the instructions or follow the safety instructions could result in serious injury or death. This manual describes conditions and hazards that are common and anticipated during equipment operation. No manual can address all conditions which may occur.

## Safety Symbols

The manual may contain one or more safety symbols. These symbols and the associated text warn you of potentially hazardous conditions. Examples of the safety symbols and the associated text follow:



**DANGER**

**DANGER:** Indicates a hazardous situation that, if not avoided, will result in serious injury or death.



**WARNING**

**WARNING:** Indicates a hazardous situation that, if not avoided, could result in serious injury or death.



**CAUTION**

**CAUTION:** Indicates a hazardous situation that, if not avoided, could result in minor or moderate injury, or cause property damage.



**GLASSES**

**SAFETY GLASSES:** Indicates a hazardous situation that requires the use of safety glasses.



**HOT SURFACE**

**HOT SURFACE:** Indicates a hazardous situation that hot surfaces may be present.



**GLOVES**

**GLOVES:** Indicates a hazardous situation that requires gloves.



**SHOCK HAZARD**

**ARC FLASH & SHOCK HAZARD:** High voltage. Entry by authorized personnel only. Appropriate PPE and tools required when working on this equipment.



**READ MANUAL**

**READ MANUAL:** Read manual before use, refer to manual for Tri Tool Technologies machine being used.



**DISCONNECT FROM POWER**

**DISCONNECT FROM POWER:** Disconnect main plug from electrical outlet before performing all maintenance.

## 2. SAFETY PRECAUTIONS

### In General

Use standard safety equipment such as: hard hats, safety shoes, safety harnesses, protective clothes, and other safety devices when appropriate.

Operate this tool only in accordance with specific operating instructions.



**WARNING: Do not override the deadman switch on the power unit. Locking down, obstructing, or in any way defeating the deadman switch on the power drive unit may result in serious injury.**

### Personal Protective Equipment

Use standard safety equipment such as: hard hats, safety shoes, safety harnesses, protective clothes, and other safety devices when appropriate.

Wear safety glasses.

Do not wear loose clothing or jewelry.

Wear nonskid footwear.

Put long hair in a cap or a net to make sure hair does not get tangled in equipment.

### Personnel

Only personnel who are trained or are being trained may operate the equipment.

Keep the operation manual available where the equipment is used.

The operator must read the operation manual before using the equipment.

The equipment must be operated in accordance with the manual information.

The operator must follow the safety precautions in this manual and good engineering practices to reduce the risk of injury.

Before using the equipment, the operator must ensure that all safety messages on the equipment are legible.

### Work Area

Keep the work area clean.

Keep the area well lit.

Keep items such as electrical cords, cables, rags, rigging straps, away from rotating equipment.

Do not use power-cutting tools in the presence of flammable liquids and gases.

Do not let visitors or untrained personnel near tools that are in use.

Ensure all observers wear eye protection.

Keep proper footing at all times.

## **Area Equipment**

Secure the pipe with clamps, vises, chains or straps.

Ensure that both sides of the pipe at the cut site are fully supported so that the pipe will not move after the cut is completed. Long lengths of pipe may be under load and the separation of the pipe can release pressure. This pressure can cause both sides of the pipe to move.

## **Tool Care**

Keep tools in good operating condition. Sharp tool bits perform better and are safer than dull tool bits.

Do not use damaged tools. Always check your tools for damage especially if a tool has malfunctioned, been dropped or hit, check it for damage.

Before you start operating the equipment, do no-load tests and feed function checks.

## **Tool Use**

Use the right tool and tool bit for the job. Contact Tri Tool Technologies to help with your application.

Keep the tool bits fully engaged in the tool bit holders. Loose bits are sharp and can cause cuts or punctures.

Disconnect power supply during setup and maintenance. Use all 'Stop' or Shut off' features available when changing or adjusting tool bits, maintaining the tool, or when the tool is not in use.

Remove adjusting keys and wrenches before applying power to the equipment. Check the tool before turning it on to make sure that all keys and wrenches have been removed.

Do not force tools. Tools and tool bits function better and safer when used at the recommended speeds.

Do not reach into rotating equipment.

Do not reach into the rotating head stock to remove chips, to make adjustments, or to check the surface finish.

Handle chips with care. Chips have very sharp edges and are hot. Do not try to pull chips apart with bare hands.

Store tools properly. Disconnect tools from the power source, remove the tool bits, and store in a safe place.

### **3. GENERAL DESCRIPTION**

The Model 300MF MICROFACER™ Tube Squaring Tool is designed specifically to prepare tubes for autogenous welding.

The 300MF MICROFACER™ will face (square) .125" to .750" (3.2mm to 19.1mm) outside diameter tubing with a wall thickness up to .125" (3.2mm).

The 300MF MICROFACER™ uses an OD Saddle Clamping System for holding and rounding the tube.

The 300MF MICROFACER™ accepts its own torque through the Saddle Clamping System. The standard Saddle Clamping System requires a straight length of tube .22" (5.6mm) long.

Speed control is provided with a variable-speed cordless electric drive.

Feed is provided by a cam-actuated feed handle at right angles to the Cutting Head.

### 4. SPECIFICATIONS

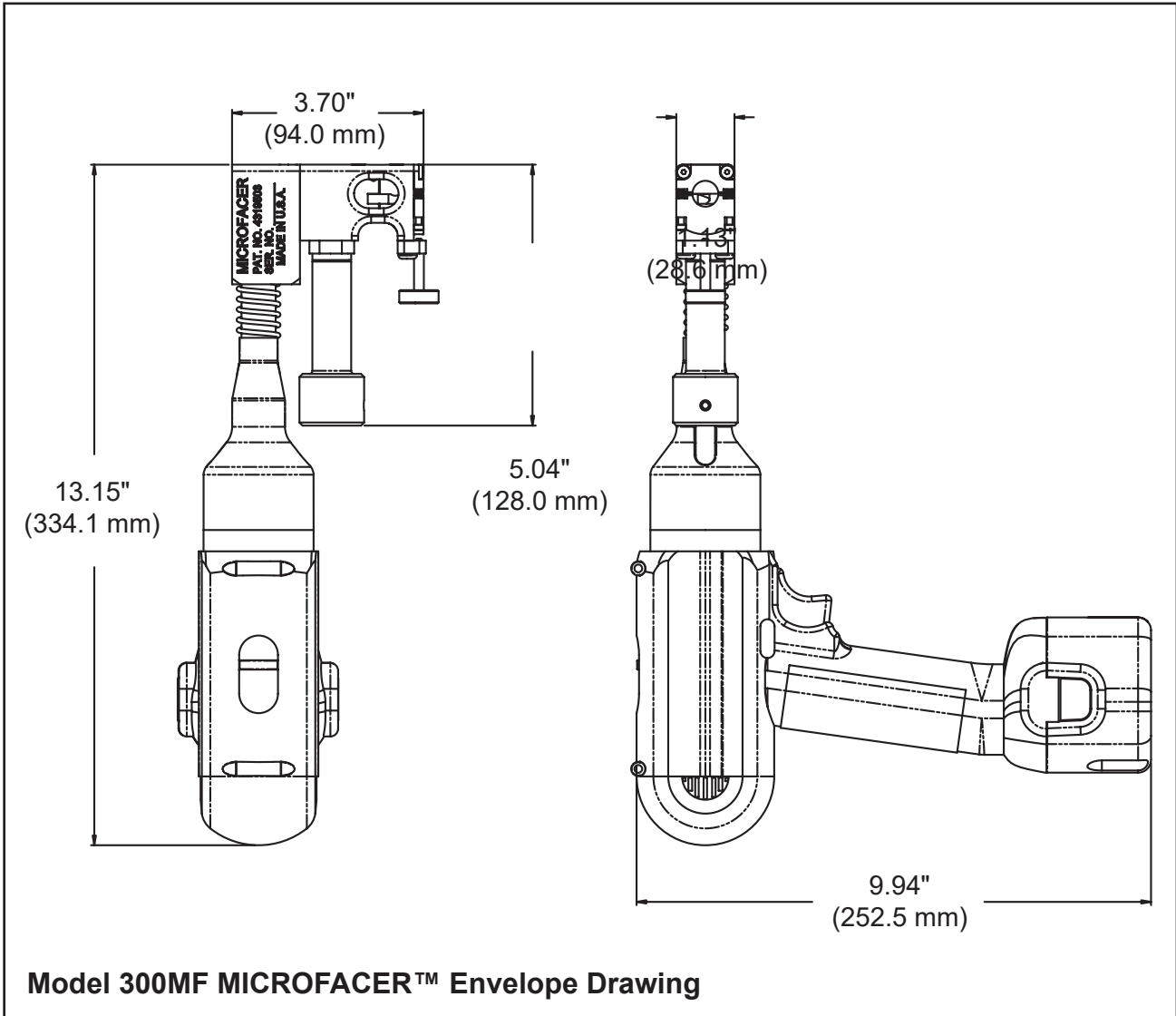

## 5. MAINTENANCE

All components should be cleaned and coated with a light film of oil prior to use.

Use a clean, non-detergent oil, preferably SAE 10 (90 SSU) or lighter.

When the Model 300MF MICROFACER™ is operated in the vertical position, Cutting Head up, it should be turned upside down and the chips and/or other debris removed after each tube squaring operation has been completed.

**NOTE: Tool life may be severely shortened, unless chips and/or other debris that have been deposited on the cutting head during the machining operation are removed.**

## 6. OPERATION

Read the operating instructions carefully before attempting to operate the Model 300MF MICROFACER™ Tube Squaring Tool.

Use eye protection at all times when operating the Model 300MF MICROFACER™.

### Installing The Saddle Set

Select the Saddle Set which is the proper size for the OD of the tube which is to be machined.

Squeeze the Saddle Set to compress the springs and insert the Saddle Set into the front of the Model 300MF MICROFACER™.

Retain the Saddle Set by inserting the two (2) cap screws into the front of the Saddle Set.

### Installing The Tool Bit

Select the Tool Bit to be installed.

Slide the Tool Bit into the slot on front of the Main Shaft.

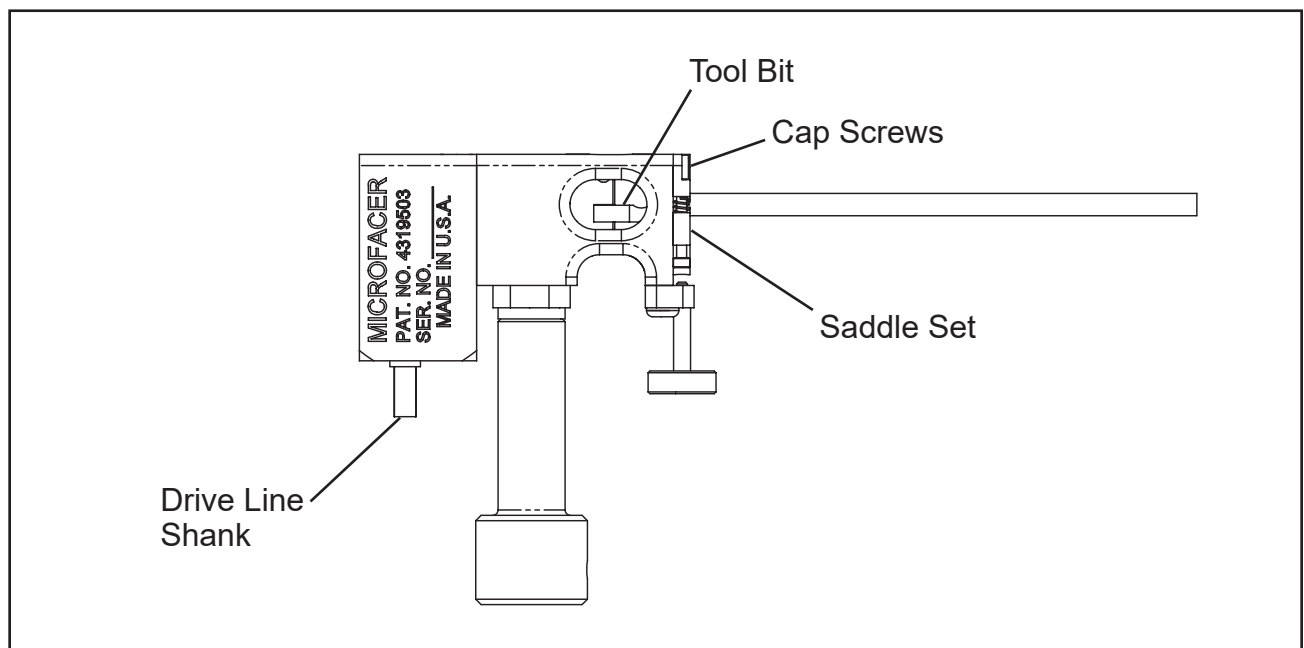

## **Installation**

Slide the tube to be worked on into the Saddle, leaving approximately 1/8" (3mm) between the Tool Bit and the end of the tube.

Tighten the Saddle Set by turning the Clamp Knob below the Saddle Set.

## **Machining Sequence**

Turn the motor on and let it slowly rotate to ensure that the Tool Bit does not make contact with the end of the tube at this time.

Loosen the Clamp Knob to release the Saddle Set and remove the machined tube.

## 7. CUTTING SPEEDS AND FEEDS

True DIA		RPM for 200 in/min (5080 mm/min)	RPM for 250 in/min (6350 mm/min)	RPM for 300 in/min (7620 mm/min)
.125"	3.18mm	509	636	763
.250"	6.35mm	255	318	382
.375"	9.53mm	170	212	255
.500"	12.70mm	127	159	191
.625"	15.88mm	102	127	153
.750"	19.05mm	85	106	127

Use 200 surface inches per minute (5080 surface millimeters per minute) for:

- Stainless steels in general when no coolant is allowed, all heavy-wall tube and some chrome/molybdenum steels.

Use 250 surface inches per minute (6350 surface millimeters per minute) for:

- Mild steels and some thin-wall stainless steels when coolants are permitted and applied.

Use 300 surface inches per minute (7620 surface millimeters per minute) for:

- Aluminum and some thin-wall mild steel and tube with coolants.

### Basic Feed Recommendation

Use very light feed for initial beveling or until a continuous cut is established.

This is very important for longer Tool Bit life when cutting through flame cut or out of square pipe ends.

Use adequate feed, .003" to .006" (.08mm to .15mm) per revolution thereafter, to establish a continuous chip cut.

- If the feed is too light, only light stringer chips will be removed.
- If the feed is too heavy the drive will start to overload and the chip will start to have a rough or torn appearance.

## 8. SADDLE SETS

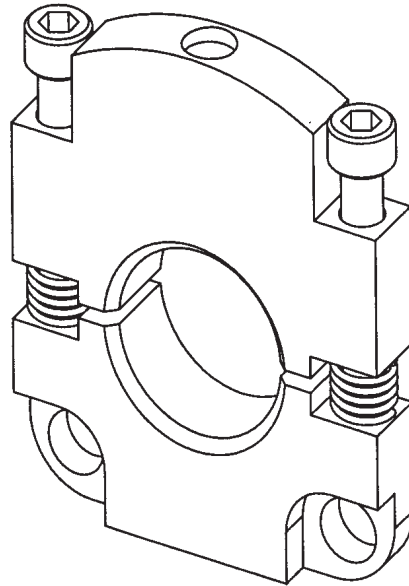

Pipe Size	Fraction	Decimal	Metric	Saddle P/N
	1/8"	.125"	3.18mm	67-4193
	5/32"	.156"	3.96mm	67-4194
		.158"	4.00mm	67-4195
	3/16"	.188"	4.76mm	67-4196
		.197"	5.00mm	67-4197
	7/32"	.219"	5.56mm	67-4198
		.234"	5.95mm	67-4199
		.236"	6.00mm	67-4200
	1/4"	.250"	6.35mm	67-4201
		.276"	7.00mm	67-4202
	9/32"	.281"	7.14mm	67-4203
		.283"	7.20mm	67-4204
	5/16"	.313"	7.95mm	67-4205
		.315"	8.00mm	67-4206
	11/32"	.344"	8.74mm	67-4207
		.354"	9.00mm	67-4208
		.359"	9.13mm	67-4209
	3/8"	.375"	9.53mm	67-4210
		.394"	10.00mm	67-4211
		.400"	10.16mm	67-4212
1/8"	13/32"	.406"	10.31mm	67-4213

<b>Pipe Size</b>	<b>Fraction</b>	<b>Decimal</b>	<b>Metric</b>	<b>Saddle P/N</b>
		.413"	10.50mm	67-4214
		.422"	10.72mm	67-4215
		.433"	11.00mm	67-4216
	7/16"	.438"	11.13mm	67-4217
	15/32"	.469"	11.91mm	67-4218
		.472"	12.00mm	67-4219
	1/2"	.500"	12.70mm	67-4220
		.512"	13.00mm	67-4221
		.531"	13.50mm	67-4222
		.535"	13.60mm	67-4223
1/4"		.540"	13.72mm	67-4224
		.543"	13.80mm	67-4225
		.547"	13.89mm	67-4226
		.551"	14.00mm	67-4227
	9/16"	.563"	14.30mm	67-4228
		.591"	15.00mm	67-4229
		.594"	15.08mm	67-4230
		.602"	15.29mm	67-4231
	5/8"	.625"	15.88mm	67-4232
		.630"		67-4233
		.641"		67-4234
		.656"		67-4235
		.669"		67-4236
3/8"		.675"		67-4237
		.677"		67-4238
		.681"		67-4239
	11/16"	.688"		67-4240
		.709"		67-4241
		.718"		67-4242
	3/4"	.750"		67-4243

## 9. TOOL BITS

Tool Bit, Tube Squaring, P/N 99-0591

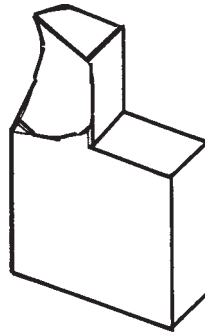

## 10. TROUBLESHOOTING

---

### **Problem: Tool Bit Chatters**

- The tool bit is loose or overextended.
  - The tool bit is damaged.
  - The tool holder is too loose in the slides.
  - The cutting speed is too fast.
  - The clamping pads are loose on the pipe or tube.
  - Cutting fluid is required.
  - The main bearing pre-load is loose.
- 

### **Problem: Excessive Tool Bit Wear**

- The pipe or tube material is too hard or abrasive.
  - The cutting speed is too fast.
  - Cutting fluid is required.
  - A dull Tool Bit is causing surface hardening conditions (Stainless pipe or tubing).
  - There is scale or other foreign matter on the pipe or tube, which is dulling the tool bit at the start of the cut.
  - The tool bit is incorrect for the material being cut.
- 

### **Problem: Rough Surface Finish**

- The tool bit is dull, chipped, etc.
  - Metal build-up on the cutting edge of the tool bit is creating a false cutting edge.
  - Cutting fluid is required.
  - The cutting speed is incorrect.
- 

### **Problem: Tube or Pipe is Slipping in the Saddles**

- The saddles are not in full contact with the pipe or tube.
  - The clamping pressure is too light.
  - Scale and/or other foreign material is present on the pipe or tube.
  - Weld seams, swelling, or bumps under the saddles are preventing full contact.
  - Dull tool bits are causing extra force in the axial and/or radial direction.
-

---

**Problem: Tool Holder Is Not Feeding**

The feed pin is broken or out of position.

The feed sprocket shear pin is broken.

The feed screw is stripped.

The feed nut is stripped.

The slide rails are too tight.

---

**Problem: Loss Of Air Power**

The air supply pressure is too low.

The air filter is plugged.

The air line size is insufficient.

The air line is too long.

---

**Problem: Loss Of Hydraulic Power**

The hydraulic supply pressure is too low.

The hydraulic filter is plugged.

The hydraulic line size is insufficient.

The hydraulic line is too long.

---

**Problem: Tool Bit Does Not Reach Work**

Incorrect tool blocks are installed for the size of the pipe or tube being worked on.

Incorrect tool bit is installed.

---

**Problem: Air Motor Does Not Start**

The air power supply is shut off.

The air motor is damaged and will not run free.

The air motor needs lubrication. Add lubrication and do not run the air motor for a few minutes, then try running the motor.

Sand or other foreign material may be in the vanes of the air motor. Tap on the side of the air motor casing lightly with a piece of wood or with a soft rubber mallet just in case the vanes may be sticking.

---

**Problem: Hydraulic Motor Does Not Start**

The hydraulic power supply is shut off.

The hydraulic motor is damaged and will not run free.

---

## 11. ACCESSORIES

The following accessories are recommended for use with the Model 300MF MICROFACER™ and are available from Tri Tool Technologies.

- Flexible Shaft Assembly (18") - P/N 14-0036
- Spare Battery, 12V - P/N 30-6570
- Charger, 110V, 12V Makita - P/N 30-6571
- Charger, 220V, 12V Makita - P/N 30-6572

**NOTE: A Filter/Regulator/Lubricator (FRL) is required to protect the warranty on all Tri Tool Technologies air-driven tools.**

## 12. MAKITA SAFETY INSTRUCTIONS

The Makita Cordless Drill/Driver comes with an 'Instruction Manual' and should be referenced for all safety and operating procedures.

# 13. RECOMMENDED SPARE PARTS

## SPARE PARTS, MODEL 300MF

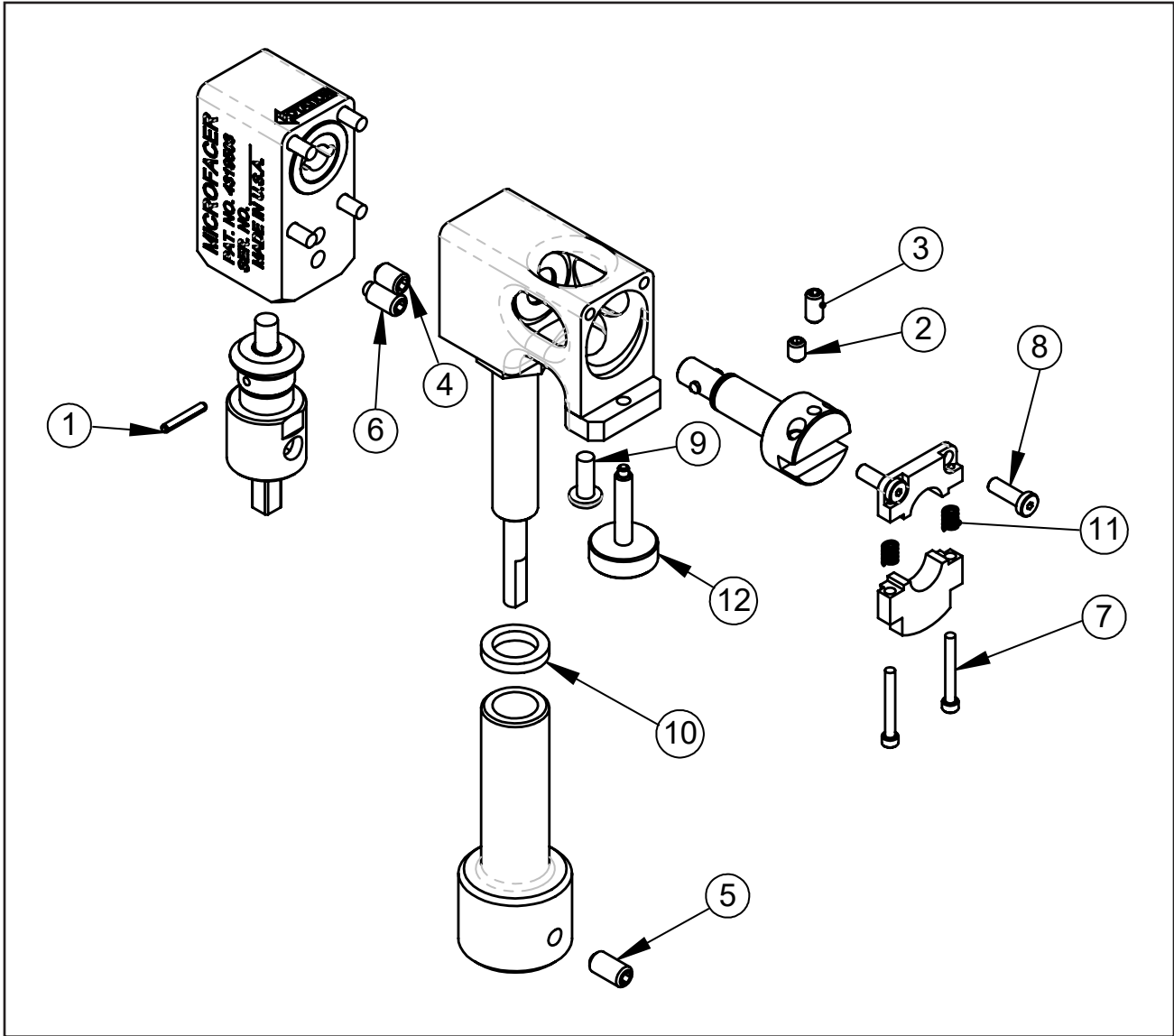

## Parts List, Spare Parts, Model 300MF

Item No.	Part No.	Description	Qty
	05-1743	SPARE PARTS KIT, MODEL 300MF	
1	32-0017	PIN, ROLL, 3/32" DIA X 5/8"	10
2	33-0488	SCREW, SET, 10-24 X 1/4" CUP PT	2
3	33-0490	SCREW, SET, 10-24 X 3/8" CUP PT	1
4	33-0501	SCREW, SET, 1/4-20 X 3/8" CUP PT	4
5	33-0503	SCREW, SET, 1/4-20 X 1/2", CUP PT	1
6	33-0927	SCREW, SET, 1/4-20 X 1/2", HDOG	1
7	33-2109	SCREW, CAP, SS, #4-40UNC X 7/8"	2
8	33-2110	SCREW, LOW HD, PL, #8-32 X 1/2"	2
9	33-2112	SCREW, BH, SS, 10-24 UNC X 1/2"	2
10	34-0060	WASHER, FLAT, DEL, 1/2" X 3/4" X 1/8"	1
11	40-0236	SPRING, COMP, .240" DIA X .688" LG	2
12	42-0175	KNOB, SADDLE ADJUST	1

# 14. ILLUSTRATED PARTS BREAKDOWN

## MODEL 300MF MICROFACER™ BODY ASSEMBLY (P/N 02-2297)

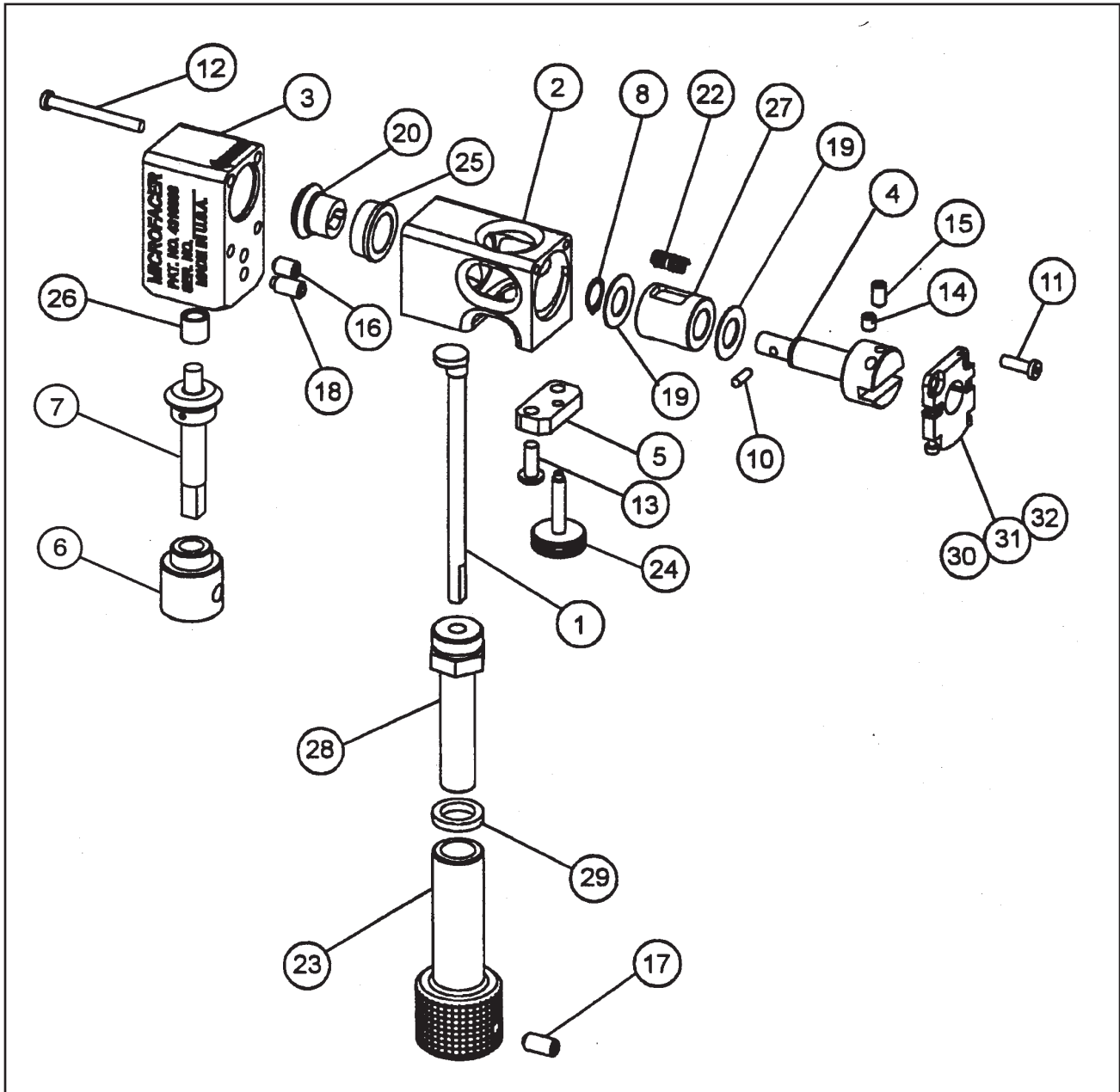

## Parts List, Model 300MF MICROFACER™ Body Assembly (P/N 02-2297)

Item No.	Part No.	Description	Qty
1	14-0006	SHAFT ASSEMBLY	1
2	19-0838	HOUSING, MAIN	1
3	19-0796	HOUSING, DRIVE	1
4	20-0718	SHAFT, MAIN	1
5	24-1614	PLATE, CLAMP	1
6	27-0584	ADAPTER, DRIVE BUSHING	1
7	27-0725	ADAPTER ASSEMBLY, CABLE DRIVE	1
8	30-0302	RING, RETAINING, EXTERNAL	1
10	32-0514	PIN, DRIVE, 1/8" DIA	1
11	33-2110	SCREW, CAP, #8-32 X 1/2"	2
12	33-2121	SCREW, CAP, #8-32 X 1 1/2"	4
13	33-2112	SCREW, BUTTON, #10-24 X 1/2"	2
14	33-0488	SET SCREW, CUP PT, #10-24 X 1/4"	2
15	33-0490	SET SCREW, CUP PT., #10-24 X 3/8"	1
16	33-0501	SET SCREW, CUP PT., 1/4-20 X 3/8"	1
17	33-0503	SET SCREW, CUP PT., 1/4-20 X 1/2"	1
18	33-0927	SET SCREW, HALF DOG, 1/4-20 X 1/2"	1
19	34-0351	WASHER, THRUST	2
20	39-0828	GEAR, BEVEL, MAIN	1
22	40-0236	SPRING, COMPRESSION	1
23	42-0174	HANDLE	1
24	42-0175	KNOB, SADDLE ADJUST	1
25	45-0306	BUSHING, MAIN	1
26	45-0296	BUSHING, BRONZE	
27	46-0462	SLEEVE, MAIN	1
28	46-0479	SLEEVE	1
29	34-0060	WASHER	1
30	67-XXXX	SADDLE SET	REF
31	33-2109	SCREW, CAP, #4-40 X 7/8"	REF
32	40-0236	SPRING, COMPRESSION	REF
<i>NOT SHOWN</i>			
	36-0002	WRENCH, L, 5/64" HEX	1
	36-0003	WRENCH, L, 3/32" HEX	1
	36-0016	WRENCH, T, 3/32" HEX	1

### 300MF MICROFACER™ MOTOR ASSEMBLY (P/N 58-0379)

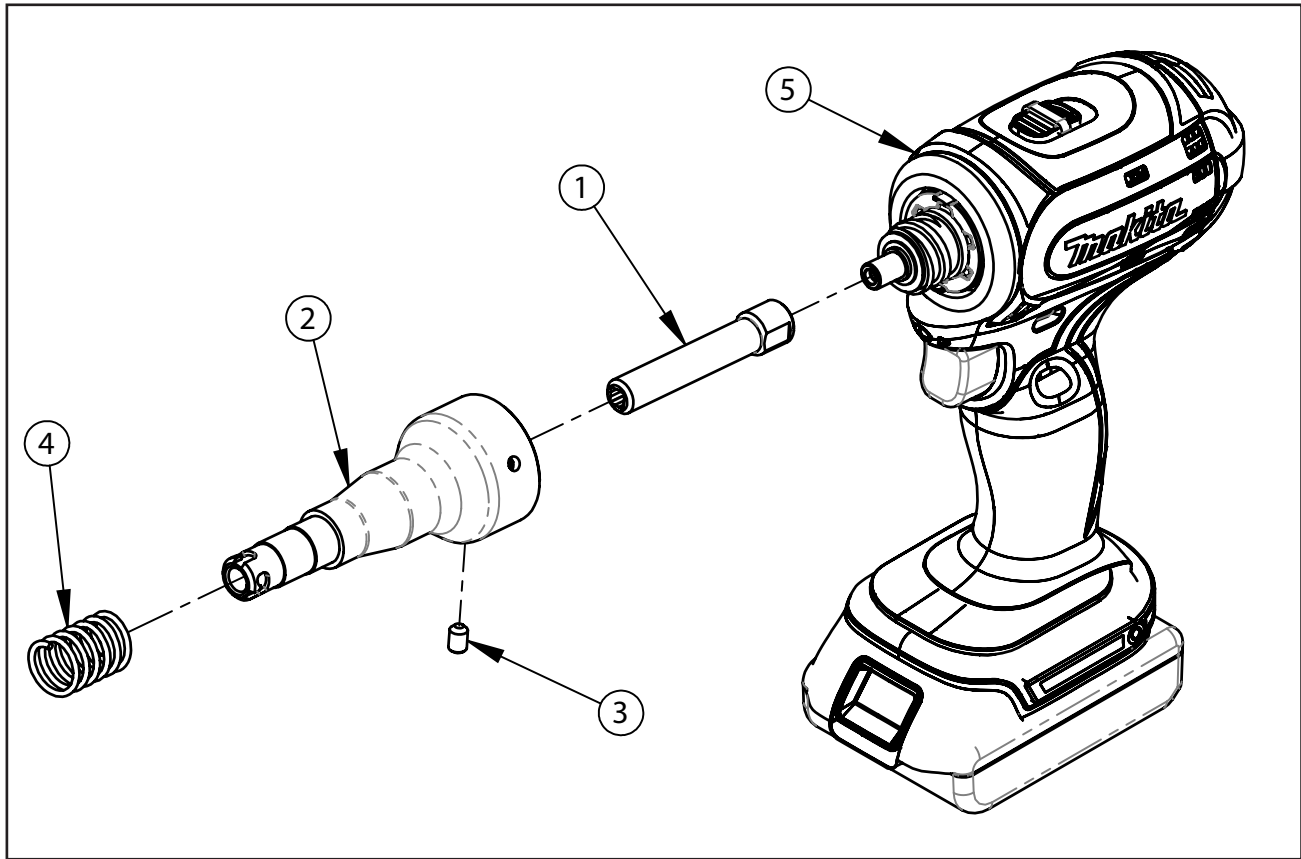

Parts List, 300MF MICROFACER™ Motor Assembly (P/N 58-0379)

Item No.	Part No.	Description	Qty
1	20-0911	SHAFT, DRIVE	1
2	27-1559	ADAPTER, BAYONET	1
3	33-0501	SCREW, SET, 1/4-20 X 3/8" CUP PT	3
4	40-0143	SPRING, MUSIC WIRE, LC 085K 03M	1
5	58-0344	MOTOR, ELECTRIC, 12V, MAKITA, MOD.	1

**REVISION HISTORY**

ADDED 11/15/2024:

<b>Description</b>	<b>Page</b>
ADDED "RECOMMENDED SPARE PARTS" SECTION, INCLUDING: SPARE PARTS, MODEL 300MF	20/21



# WARNING



Read the manual and be familiar with all safety precautions before operating equipment. The following are general warnings for industrial equipment with moving parts. Refer to the manual for specific warnings applicable to your equipment.



**EYE HAZARD** - Always wear appropriate eye protection while operating the equipment.



**PINCH HAZARD** - Keep your hands and clothing away from moving parts.



**CRUSH HAZARD** - The machinery, pipe, or work piece can shift, separate, lurch, or fall.



**CHIP HAZARD** - Metal chips may be hot and sharp. Be careful when you clear the tooling path or clean up chips.



**TIE DOWN HAZARD** - Deliberate overriding of safety triggers can result in serious injury. Never lock or tie down any safety triggers.



**SHOCK HAZARD** - Ensure that the equipment is properly installed and grounded. Ensure that the equipment is not damaged and that the power cord is intact.

## OTHER HAZARDS

- Tool bits are sharp and can cause serious injury.
- Do not defeat or modify safety features.
- Disconnect power sources before servicing or moving the equipment.
- Remove all loose articles of clothing and jewelry before operating the equipment.

***Be Safety Conscious!***



3041 Sunrise Blvd.  
Rancho Cordova, CA 95742  
+1(916) 288-6100 • +1(800) 345-5015  
[www.tritool.com](http://www.tritool.com)